



Front Security



HARMONICA HEKKEN



HARMONICA HEKKEN

Harmonica hekken bestaan uit stalen verticale lamellen die als een 'gordijn' kunnen worden geopend. Ze zijn ideaal voor het scheiden van grote ruimtes zoals bijvoorbeeld winkelcentra, luchthavens, beurzen, scholen, receptiehalles en elke toegang zowel intern als extern.

Belangrijkste kenmerken

- Onbeperkte breedte
- Zeer makkelijke installatie
- Geen geleider aan de onderkant
- Mogelijk om met een ronde gevel mee te lopen
- Benodigde ruimte van de bovenrail (39 x 39 mm)

Bouwkenmerken

De afwezigheid van een onder geleider laat de vloer volledig vrij van obstakels. De modulaire constructie maakt het mogelijk om extreem grote breedtes zonder installatie- en transportproblemen te creëren.

Gebruik

Het systeem wordt geopend door de lamellen eenvoudig naar de zijkant te duwen. De lamellen bewegen doormiddel van kogel lagers in de boven geleider. Het openen van het systeem gebeurt soepel en stil.

Materialen en afwerkingen

- Gegalvaniseerd staal of RAL kleur naar keuze
- Technische geanodiseerd aluminium of in RAL kleur naar keuze
- RVS (AISI 304 - AISI 316)

FoldingPACK® is the new horizontal sliding folding closure ideal to separate large areas and to protect them using a safety and easy use dividing system. Its use is advised for mall galleries, airports, exhibitions, reception and all internal or external accesses.

More relevant characteristics:

- Illimitate width
- Very easy installation and minimally invasive
- Reduced encumbrances
- Linear or curvilinear sliding

Required spaces

- Minimum size of top-hung track (39 x 39 mm)
- Reduced encumbrance of side stack
- No lower track on the floor.

Construction characteristics:

The absence of lower track leaves the floor completely free from encumbrances. The modular construction allows to realize also large widths without installation problems and transport.

Operation

The side-sliding is possible with simple manual push through wheels with ball bearings inserted in the top-hung track. The manual operation is flowing and noiseless.

Materials and finishes

- galvanized steel or painted in RAL colors;
- aluminium mill finish or painted in RAL colors
- stainless steel (AISI 304 or AISI 316)

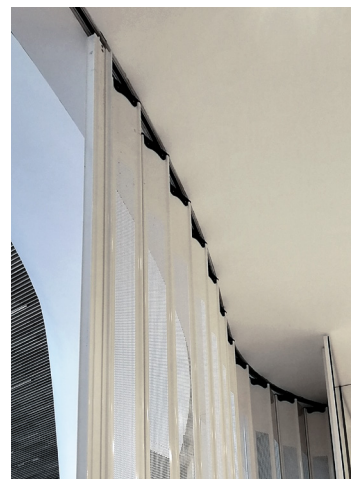



NIEUWE HARMONICA HEKKEN DOOR INNOVATIE

Standaard microboringen

De standaardoplossing voorziet de lamellen volledig van micro-perforatie, met uitzondering van het onderste en bovenste gedeelte dat dicht blijft om de sluiting veiliger te maken en het zorgt ook dat het systeem stevig kan worden bevestigd.

Microboringen op maat

Het is mogelijk om zelf te bepalen hoe veel en met welke interval de microperforatie wordt geplaatst. Hierdoor kan bijvoorbeeld het doorzicht naar binnen deels worden geblokkeerd.

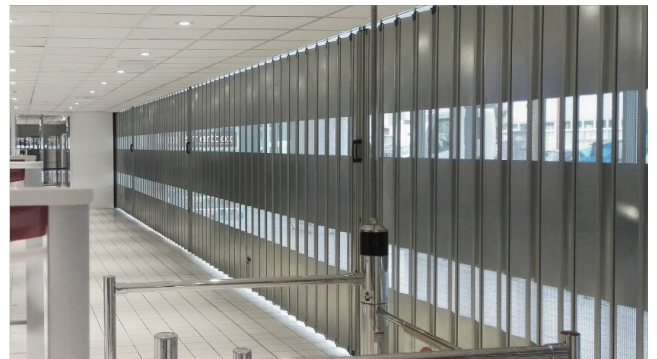

Standard micro-perforation

The standard solution provides the elements entirely micro-perforated with the exception of a lower and upper section that remains blind to make the closure more secure and allow the various accessories to be fixed on a solid surface.

Custom micro-perforation

In relation to the requests it is possible to customize the aesthetics of the shutter by realizing the micro-drilling in the positions and with the "blind / perforated" intervals indicated by the customer.



Standaard microgeperforeerd
microperforated

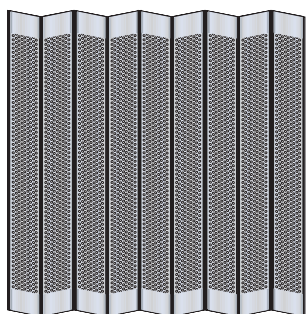

Microgeperforeerde lamellen
Microperforated WALL

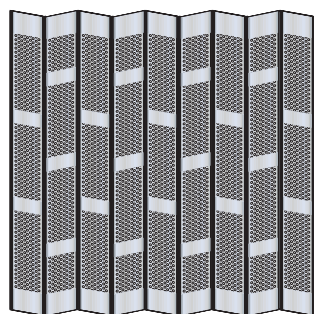

Aangepaste microperforatie
Custom micro-perforation

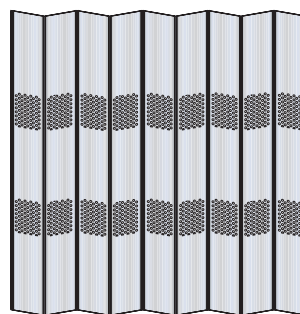

Gesloten lamellen
Full slats

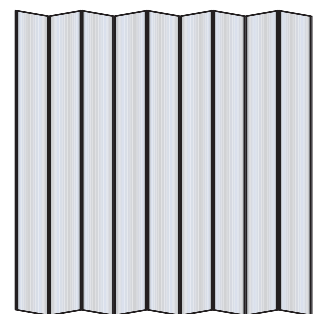



B = Totale breedte **W** = Total width

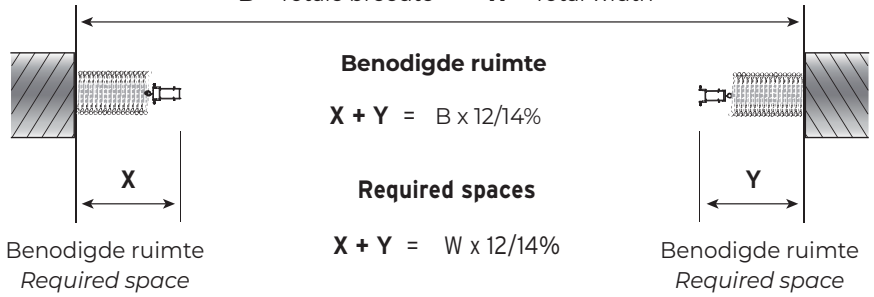

Bovenrail
 Top-hung track



Midden sluiting
 Central lock

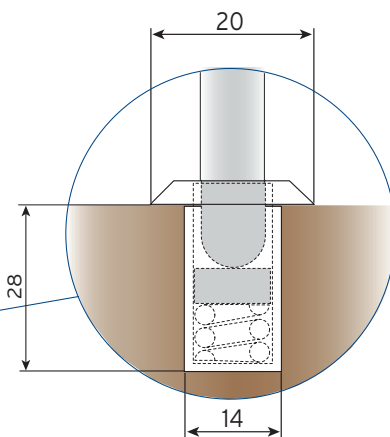
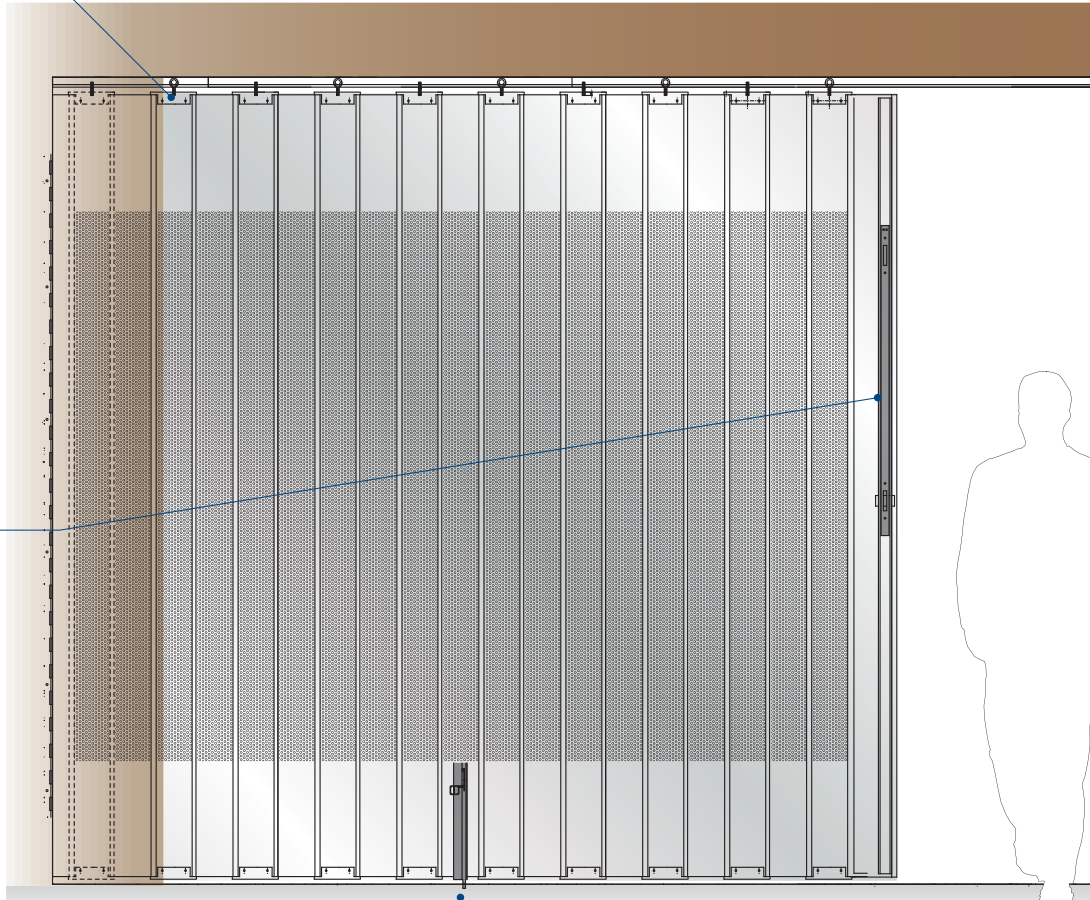

De vloerbevestiging van RVS bevat een stofkap die het veermechanisme beschermt

Stainless steel floor socket contains a dust cap that protects the spring mechanism underneath

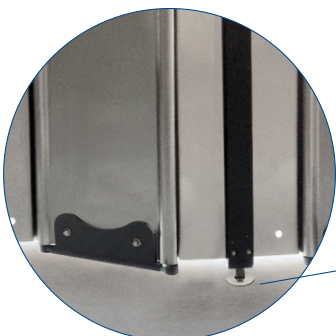

Klink met borgpen
 Latch with locking pin



Bovenrail bevestiging
Guide junction

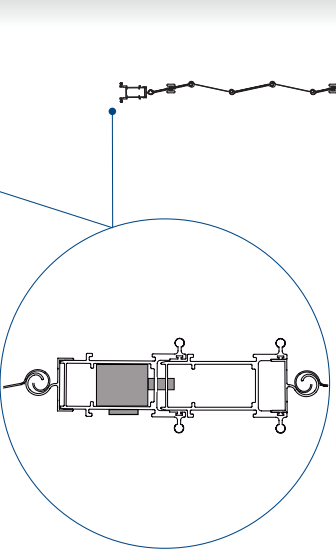
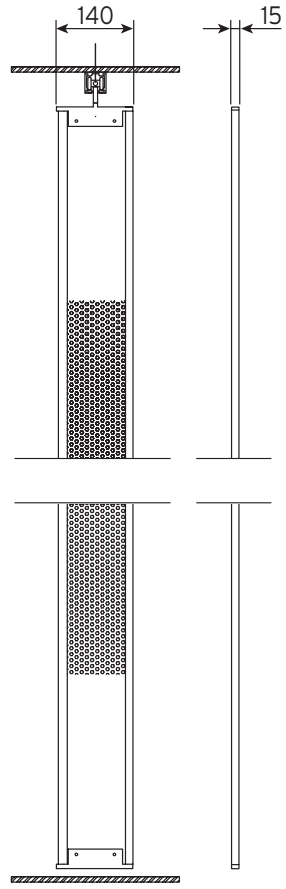
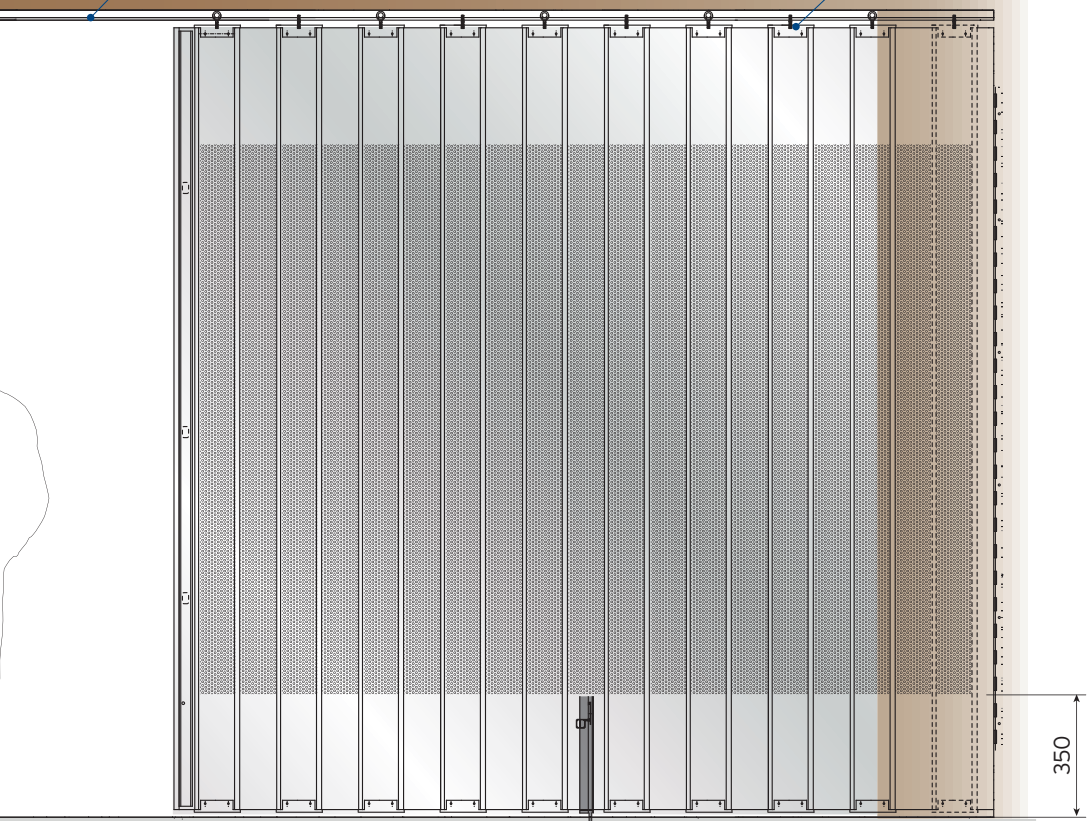
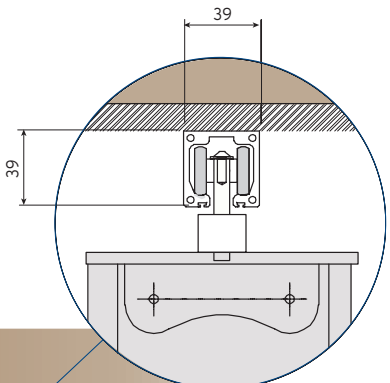
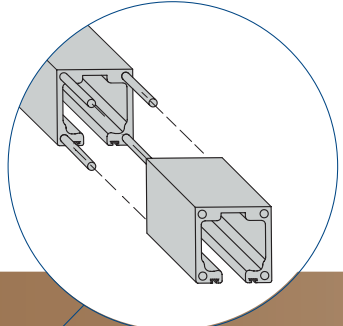

De geëxtrudeerde aluminium profielen maken het inbrengen van sloten mogelijk voor nauwkeurige en veilige tegenvergrendeling

Extruded aluminum profiles allow the insertion of locks and allow precise and safe counter-locking

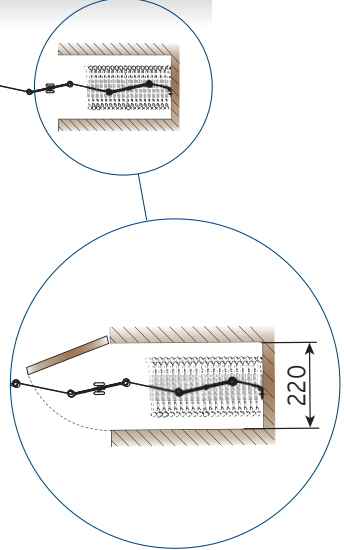

Afmeting schuifrail

Sliding channel dimension

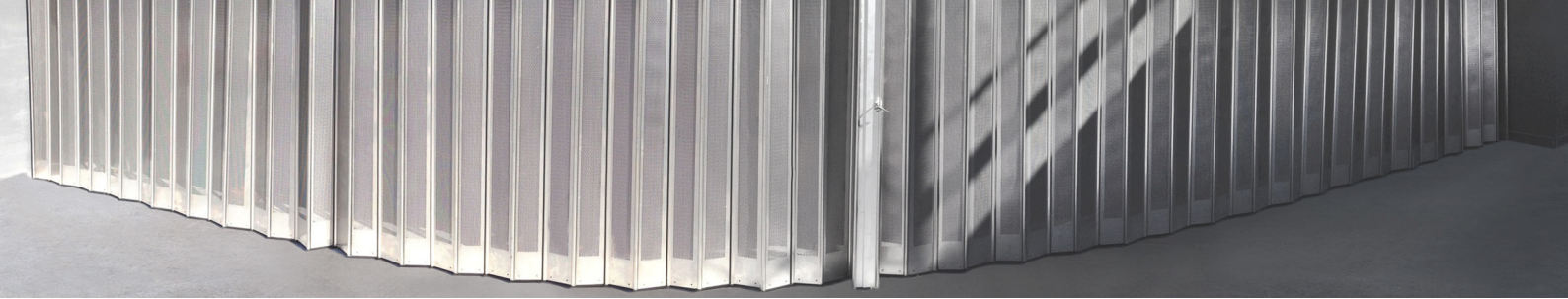

GEBOGEN HARMONICA HEKKEN CURVES AND JUNCTIONS

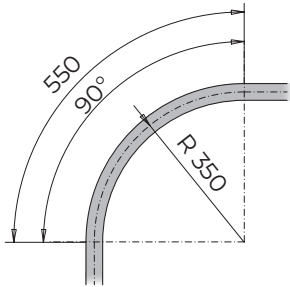

Minimale radius 350 mm.
Kleinere straal op aanvraag
*Minimum standard radius mm. 350
Smaller radius on request*

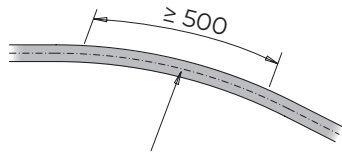

Boog lengte
minimaal 500 mm
*Minimum curve length
mm. 500*

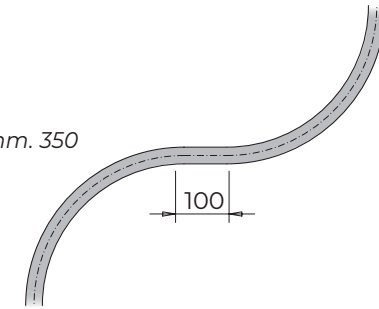

Aanbevolen tussenstuk 100
mm tussen twee bogen
*Recommended junction mm.
100 for curve change*

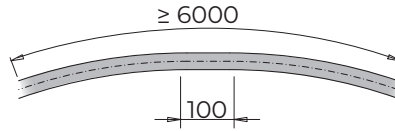

Aanbevolen tussenstuk 100
mm tussen twee bogen \geq
6000 mm
*Recommended junction mm.
100 for curves \geq mm. 6000*

VOORBEELD CONSTRUCTIES SAMPLE LAYOUTS

Harmonica hekken kunnen worden geproduceerd met rechte of gebogen rails! Er kunnen verschillende radiussen achter elkaar worden geplaatst en zodoende kan het hek in bijna alle situaties perfect met de gevel meelopen!

FoldingPACK® fit virtually any curved and thus allow endless creativity. More complicated layouts can be achieved using a special radius curve. To close the stacking it is possible to make a box with a door integrated into the setting.



Hek met dubbele vleugel
Bi-parting straight arrangement with visible stacks



Hek met ingebouwde enkele vleugel
Stacking to one side with stack in custom build box



Hek met ingebouwde dubbele vleugel
Bi-parting with stacks in custom build boxes



Combinatie van een gebogen en
recht hek
*Bi-parting with custom curves
combined with straight sections*



Combinatie van een gebogen en
recht hek
*Bi-parting with custom curves
combined with straight sections*



Front Security - onderdeel van De Leeuw Protection Systems

De Leeuw Protection Systems is een toonaangevende leverancier van MULTIFILM binnenzonwering, SECURFOL Raamfolie en Front Security beveiligingshekken, rolhekken en rolluiken. Wij beschermen mensen, bedrijven en goederen door het creëren van innovatieve producten die stuk voor stuk zekerheid, veiligheid en gemak bieden. Onze jarenlange ervaring maakt ons de specialist op dit gebied. Langdurige relaties met opdracht-gevers, onderaannemers, leveranciers en medewerkers staan bij ons hoog in het vaandel. De Leeuw Protection Systems wil de komende jaren haar sterke positie in de markt behouden en verder uitbreiden. Dit verwezenlijken wij door continue te investeren in de innovatie van onze producten om totaaloplossingen te kunnen blijven bieden.